

Schnitt B-B

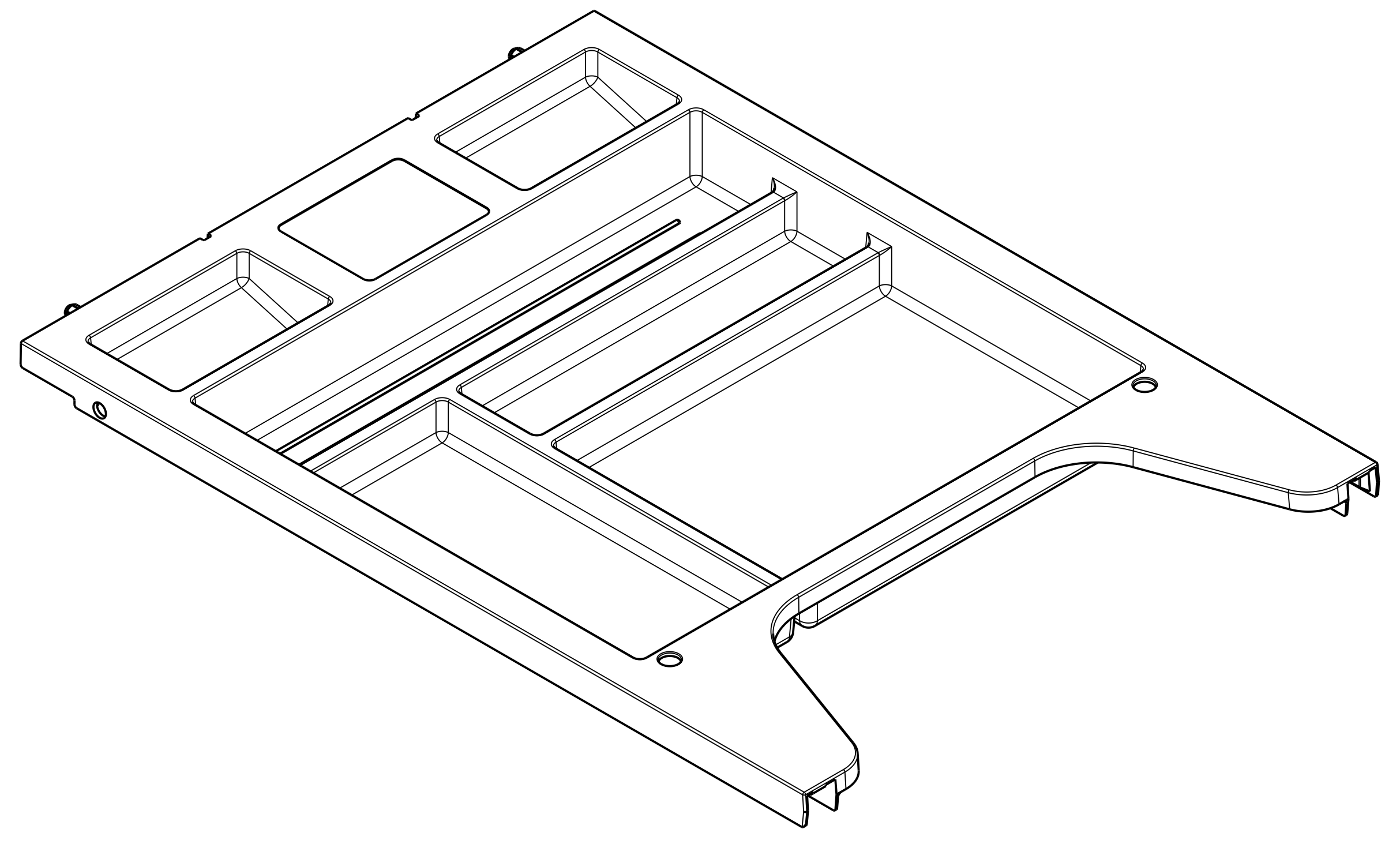

Isometrische Ansicht
M 1:2



Bezeichnung:	Materialauszug OrgaAer	
Zeilungs-Nr.:	BBP 2688.02	
System:	CATIA V5 R32	
Stand:	Ers. fuer:	Ers. durch:
Boorb.:	Datum:	Name:
13.04.23	19.04.23	Kazem Adel
konstr.:	zul. Abw. fuer Messung ohne Toleranzang.	
19.04.23	Kazem Adel	
Techn.:	Material:	PS
	Resultab.:	1:1 (1:2)
	Anz.:	.
	Nr.:	.
	Gewicht:	0,520kg
	Blatt:	